

Since 1898
CONSEW®

CONSOLIDATED SEWING MACHINE CORP.

└ INDUSTRIAL SEWING & CUTTING EQUIPMENT

MODEL 1118-3

BLINDSTITCH

INSTRUCTIONS

&

PARTS LIST

Intentionally left blank

STANDARD SIZE NEEDLES

- #10 Fine knit rayon
- #15 Fine knit wear
- #20 Fine knit jersey
- #25 Dresses and light fabrics
- #30 For sportswear
- #35 For heavy, hard material and coats
- #40 For extra hard material

MOUNTING MACHINE

1. Fasten machine to table using felt pad. Tighten screws evenly, turning each a little at a time.
 - a. When an individual motor and clutch unit is employed, it is recommended that the motor be rated at $\frac{1}{3}$ HP and 1725/1750 RPM. On all standard models, use a $3\frac{1}{2}$ " outside diameter pulley. On models intended for alteration, use a $2\frac{1}{2}$ " outside diameter pulley.
 - b. When the machine is mounted on a power table, a 4" pulley should be used. If possible, when using such stands, the machine should be mounted TO AVOID CROSSING THE BELT.
 - c. The maximum machine speed recommended for any installation is 3000 RPM, unless otherwise specified.
2. The handwheel's direction of rotation is away from the operator. It rotates in a **clockwise** direction when looking at the face of the wheel pulley, as shown by the arrow.
3. Either V-belting or round leather belting may be used. Excessive tension of belt will cause over-heating and freezing of bearing at hand-wheel.

CAUTION: BEFORE OPERATING MACHINE, LUBRICATE IN ACCORDANCE WITH INSTRUCTIONS. REFER TO OIL CHART.

1. Place a few drops of oil at all points shown on the oiling chart. All moving parts **MUST** be oiled.
2. In production use, the machine should be oiled twice daily

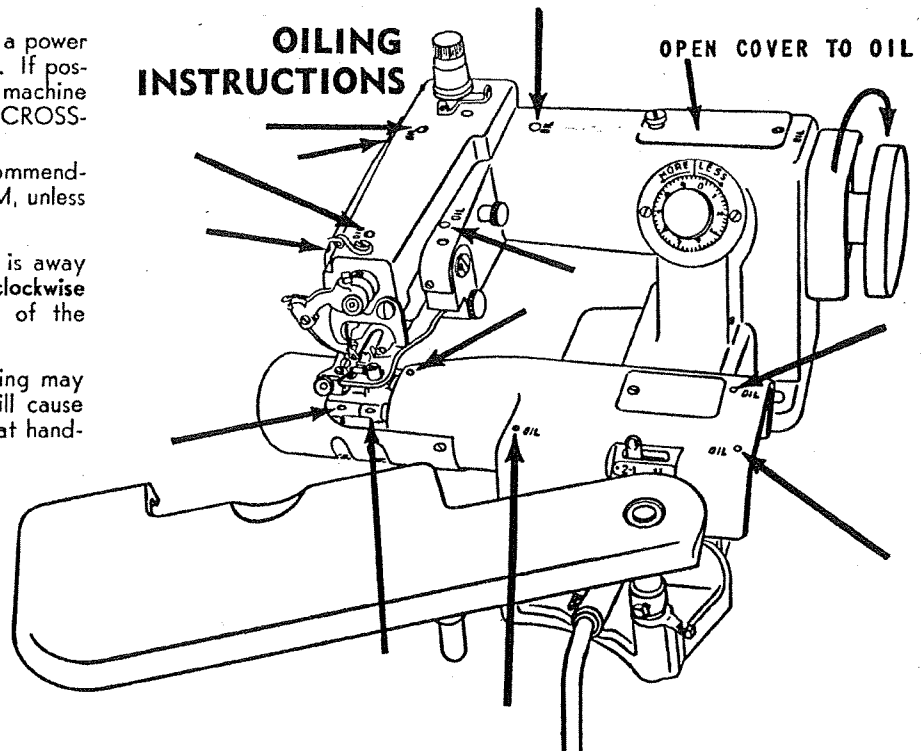

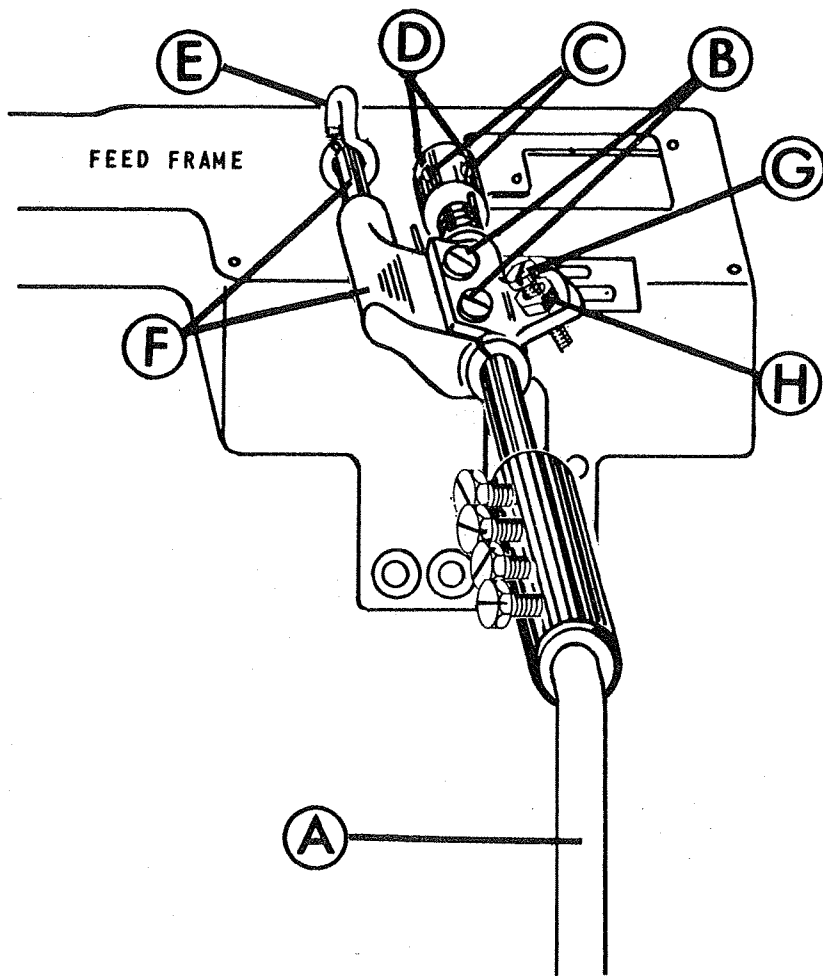

KNEE LIFTER ADJUSTMENT

To adjust Knee Lifter (A), loosen Lift Arm Screws (B) and bring Knee Lifter into position most comfortable for operator. Tighten Screws (B) securely.

This adjustment may require readjusting tension spring.

To adjust tension of spring on Knee Lifter, loosen Collar Screws (C) and wind spring by placing side blade of screw driver in Collar slots (D). Wind tight enough until Knee Lifter (A) swings towards the operator, then tighten Collar Screws securely.

"S" Hook (E) must always have slack between Feed Frame and Lift Arm (F). To do this, first loosen Lock Nut (H) and turn Adjusting Screw (G) left or right until "S" Hook is FREE of Feed Frame and Lift Arm. Hold Screw in place and tighten Lock Nut (H).

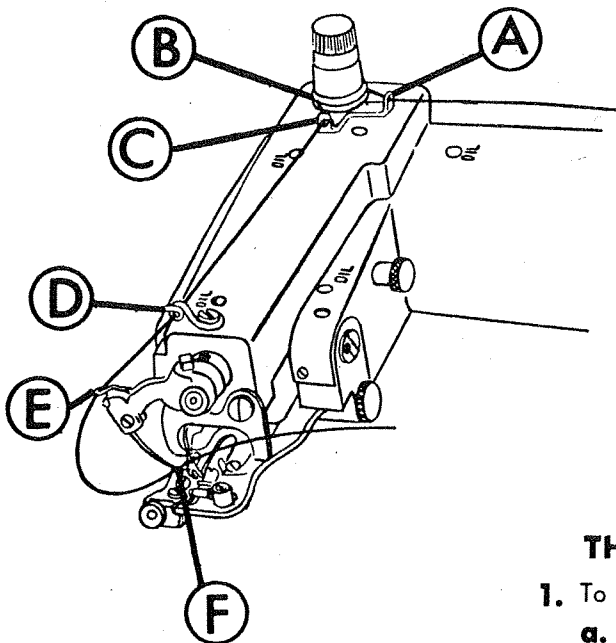

THREADING CHART

1. Use any type thread which is suitable for the fabric being sewn. This includes mercerized, 00, silk and synthetic threads.
2. The thread is passed through rear thread guide (A) then slides between two tension discs (B) through (C) through front thread guide (D) . . . then down through needle clamp hole (E) . . . and entering from the underside of needle hole (F).
3. Leave thread about 2 to 3 inches past needle hole.

THREADING NEEDLE

1. To thread needle at point (F)
 - a. Swing work plate out of way
 - b. Depress cylinder out of way with knee lifter
 - c. Hold thread between index finger and thumb
 - d. End of thread must be **stub** not feather edge.

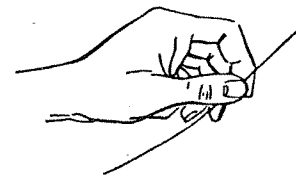

RIGHT
Up like this



WRONG
Not like this

ADJUSTING RIB TO NEEDLE

THE MACHINE SHOULD BE CHECKED TO INSURE CORRECT NEEDLE SETTING TO PREVENT DAMAGE TO NEEDLES.

1. Press knee lifter to depress feed frame.
2. Turn hand wheel **CLOCKWISE** until eye of needle is at slot in presser foot shoe (Fig. 1).
3. Slowly release knee lifter. The rib should **JUST TOUCH THE NEEDLE** (Fig. 2).
4. If rib is pressing up against needle (Fig. 3), turn dial toward "**LESS**" until rib just touches needle.
5. If rib is away from needle (Fig. 4), turn dial toward "**MORE**" until rib just touches needle.
6. When needle just touches rib (Fig. 2), machine is set to test.
7. To test machine, when ratio is set 2 to 1 ratio—take single layer of material, place in machine and turn machine by hand. If machine catches once, then does not catch on next stroke, machine is ready to work.
8. Keep dialing "**MORE**" or "**LESS**" until above results are obtained on silk or any thin goods.
9. On heavy goods, it should catch on each stroke of needle.
10. You are now ready to thread machine. Refer to 'threading instructions.

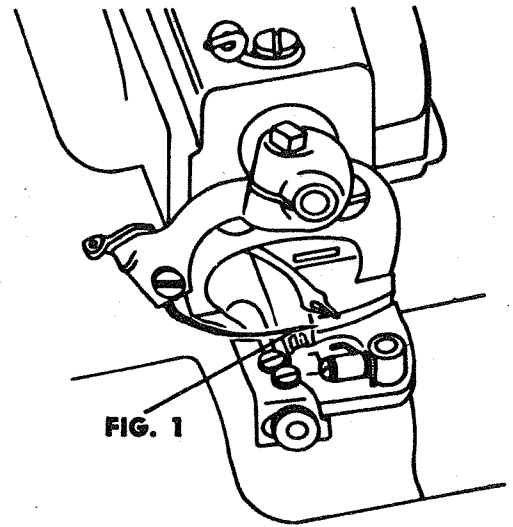

FIG. 1

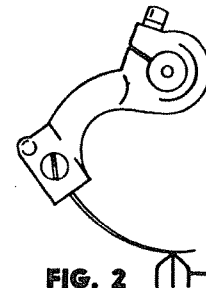

FIG. 2 Rib

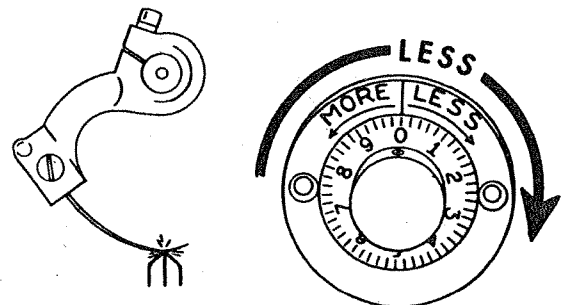

FIG. 3

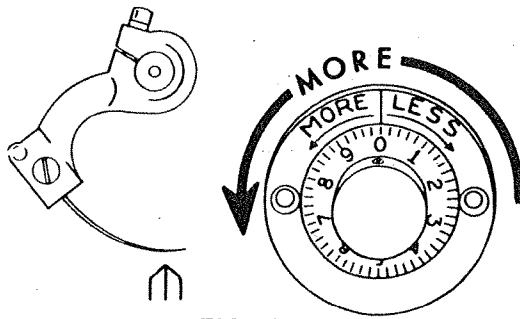

FIG. 4

TO CHANGE STITCH RATIO, DEPRESS KNEE LIFTER AND MOVE LEVER TO DESIRED STITCH RATIO

When set for

2-1	catches every other stitch
1-1	catches every stitch

IMPORTANT:

Place a piece of thin sample material in machine. Set stitch ratio on 2-to-1. Turn hand wheel clockwise by hand so that needle catches on one stroke and skips a stitch on second stroke.

ON THE SKIP STROKE, stop when the eye of the needle is at the rib (Fig. 1). At this point, the gap between the Compensating Skip Stitch Screw (Fig. 5, A) and the Push Rod (B) should be .018 (C). (In the absence of a gauge, .018 is about 5 times the thickness of average letterhead paper.) This adjustment is made by loosening Lock Nut (F), adjusting screw (A) so gap at (C) is .018. Keep screw in place with screwdriver and secure Lock Nut.

Once this is done, a similar adjustment on Feed Frame Limit Safety Screw (E) should be made. Loosen Lock Nut (D), adjust Safety Screw (E) so that gap (G) between Screw (E) and Main Frame of machine is .018. Hold Screw in place with screwdriver and secure Lock Nut. **THIS ADJUSTMENT IS TO PREVENT OPERATOR FROM MISTAKENLY ADJUSTING RIB TOO HIGH WITH "MORE/LESS" DIAL CAUSING NEEDLE TO STRIKE RIB AND BREAK.**

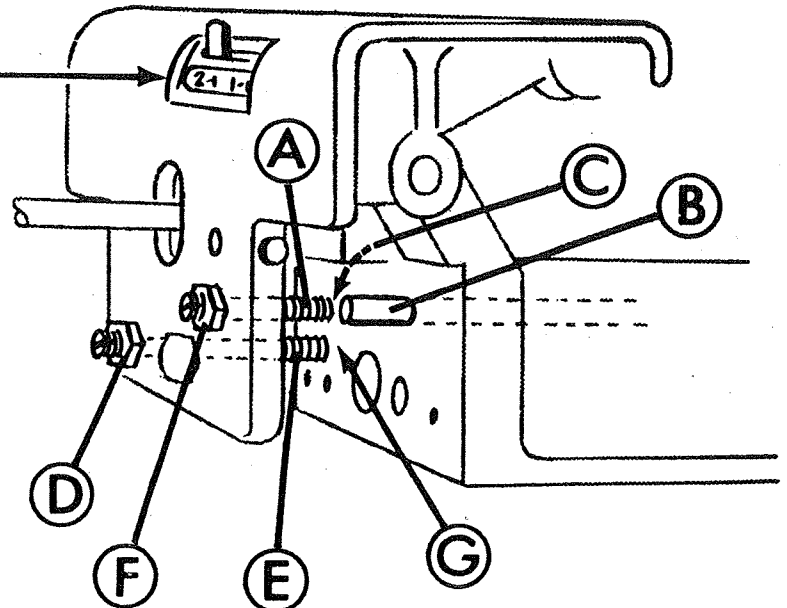

FIG. 5

TESTING NEEDLE

IMPORTANT: First test needle to make sure there is no bur or it is not bent. To check for bur, rub fingernail across point. If needle is bent, it will not rest firmly on needle guide Fig. 6. (F)

CHANGING NEEDLE

TO REMOVE

1. Loosen screw (A) about $2\frac{1}{2}$ turns until Needle Clamp (B) is loosened from Needle Lever (C) and Needle is free. (Fig. 1)
2. Hold Needle with left hand thumb and index finger, remove by moving away from you and to the left (Fig. 1). It should come out effortlessly. DO NOT FORCE.

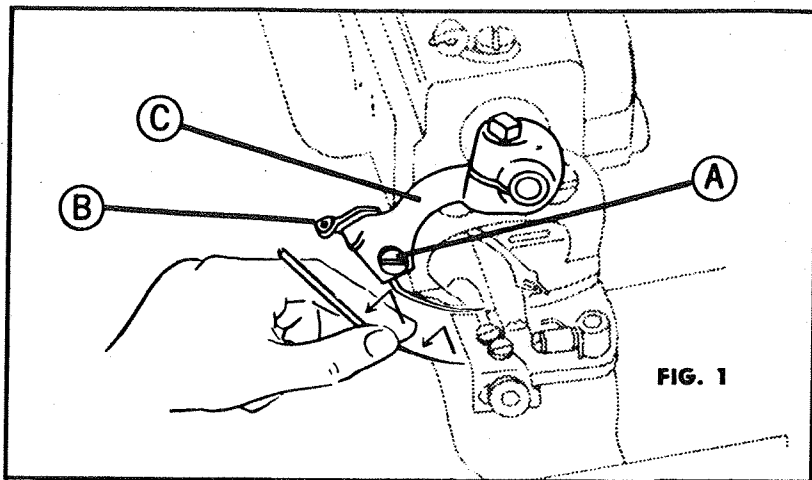

FIG. 1

INSERTING NEW NEEDLE

1. Place good new needle in groove of presserfoot and hold in place with right index finger (Fig. 2). With tilting motion of right thumb (Fig. 3), tilt shank of needle to right in between Needle Clamp (B) and Needle Lever (C) and into groove of Needle Lever.
2. With left index finger and thumb (Fig. 4), bring Needle Clamp and Lever together making sure Needle is setting in Needle Lever Groove. While holding together with left hand, draw needle up as high as possible with right hand. Then with right hand, tighten screw (A) with screw driver.
3. Hold Needle at point (D) (Fig. 5) with left thumb and index finger, loosen screw (A) a quarter turn, then push Needle all the way up the Needle Lever (DO NOT FORCE) and secure screw (A) firmly.
4. EYE of Needle should be at point (E) (Fig. 6) when Needle Lever (C) is at its highest point.

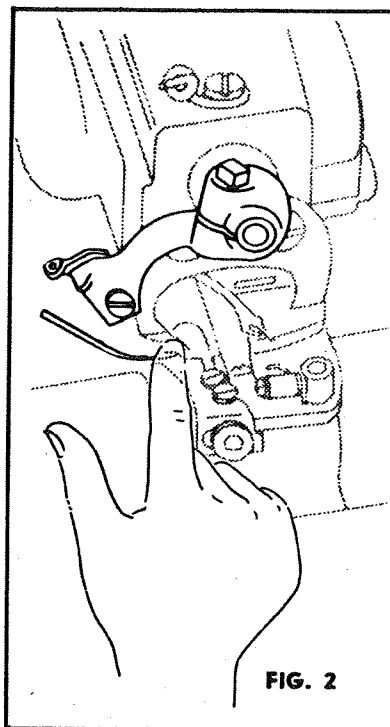

FIG. 2

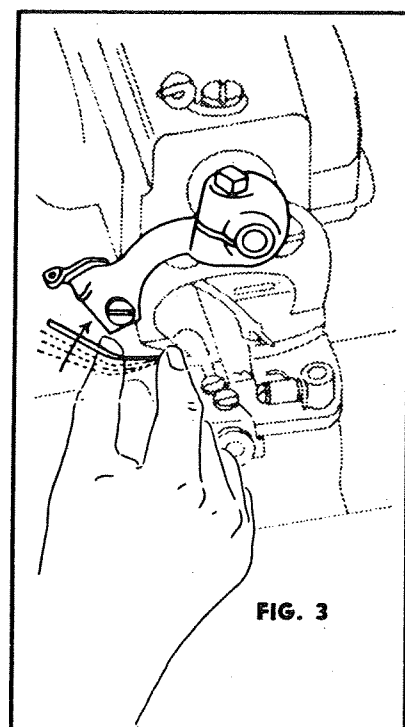

FIG. 3

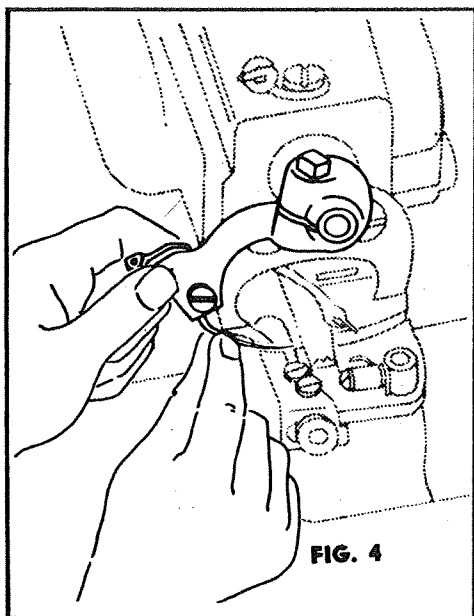

FIG. 4

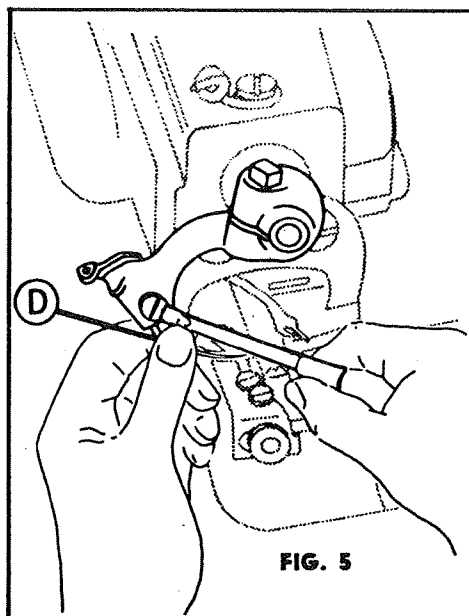

FIG. 5

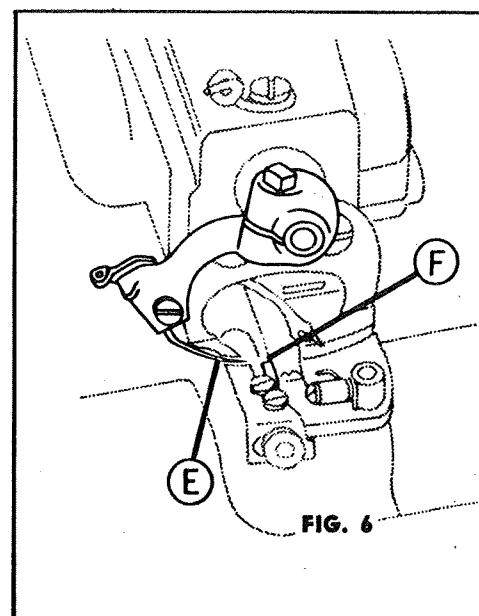

FIG. 6

HOW TO SEW

1. Turn hand wheel slowly clockwise until needle reaches high point (A).
2. With hands 12 inches or so apart (Fig. 1) hold hem firmly. Depress knee lifter, place hem in machine parallel with, and up under presser foot. (D)
3. Place edge of hem in slot of shoe (B) and at edge of gauge (C).
4. Start sewing. **IMPORTANT:** Keep edge of hem lightly, but firmly against gauge, keep material parallel to gauge by **KEEPING EYES ON GAUGE ONLY . . . NOT ON NEEDLE OR SEWING.**
5. To remove . . . make sure needle is again at high point. Depress knee lifter and pull work **AWAY FROM YOU**, straight back to break thread.

IMPORTANT—DO NOT TUG MATERIAL BACK AND FORTH OR IT WILL UNRAVEL THE STITCH.

START SEWING

1. On thin goods or ribbon cloth guide Fig. 1, (C), should be set almost at extreme right side of machine and should obtain results shown in Fig. 2. (F).
2. For heavier goods, bring cloth guide to the left as necessary.
3. Do not pull material to help feeding, do not hold material back, just hold firm but lightly.
4. To remove finished work, **MAKE SURE NEEDLE IS AT HIGH POINT FREE OF GARMENT.**

TENSION

If material puckers, loosen tension.

If thread is loose, make sure thread is between tension, discs then tighten accordingly. Do not hesitate to turn tension nut several times as needed.

On thin goods, a light tension is required. On heavier goods, a tighter tension is necessary.

IMPORTANT: Unlike a regular machine, this machine requires very little tension.

UNRAVELING STITCH

To unravel the stitching, turn hand wheel **CLOCKWISE** to high point of needle. Continue clockwise until thread is off looper. Then **COUNTERCLOCKWISE** to threading position.

Depress knee lifter and remove garment . . . thread will unravel.

To unravel stitch on finished garment, start where stitching finished, break straight thread and unravel backwards, **NOT FROM DIRECTION OF SEWING.**

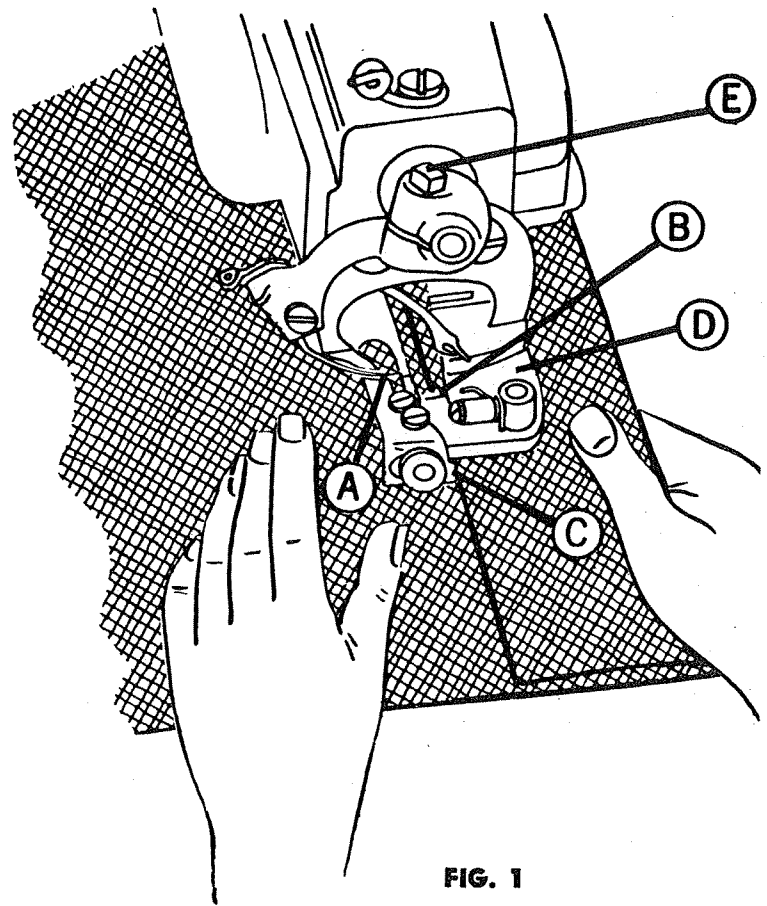
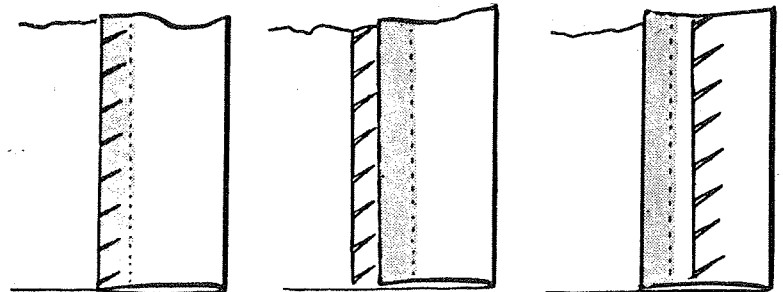

FIG. 1

PROPER STITCHING (Fig. 2)



F. Proper stitching.

G. Material running off. Bring gauge over a little to left.

H. Gauge too far to left. Move gauge over to right.

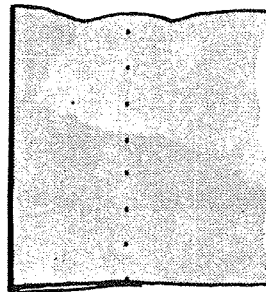

I. If catching each time on light fabric, turn dial to "LESS" until it looks like J.

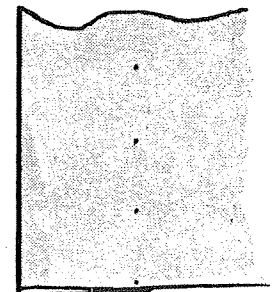

J. Catches on thin fabric every other time. (Provided needle is good.)

PROPER SETTING FOR RIB CONNECTION

Turn Handwheel clockwise until Needle is on the DOWN stroke. When Needle reaches right hand edge of Needle Guide "A" (Fig. 1), Rib "B" should STOP and SHOULD NOT MOVE UNTIL NEEDLE POINT PASSES OVER RIB TO OTHER SIDE OF PRESSERFOOT OPENING "C".

If Rib does move, make the following adjustment: First loosen Screw "A" (Fig. 2). Bring Needle Point back to right hand edge of Needle Guide. Then loosen screw "B", keeping screwdriver in place. Move Cam forward or backward until Rib is at the STOP position, **holding Needle in Position with handwheel while performing this operation.** Tighten Screw "B". Test accuracy of adjustment by repeating operation outlined in first paragraph. If still not correct, readjust by loosening screw "B" again, change angle of Cam slightly forward or backward as needed and retighten Screw "B". When adjusted satisfactorily, be sure to TIGHTEN BOTH SCREWS "A" & "B" before putting machine into operation.

TO SET RIB SHAFT

When needle is in same position as in Fig. 1, loosen Screw in Fig. 3, and turn Rib to desired position. Secure Screw. (See page 9 for closer detail of Rib Shaft if needed.)

NEEDLE STROKE

Turn Handwheel clockwise, bringing Needle to end of stroke at the right side. At this point, the Needle tip should be 5/8" to 11/16" from the right side of Presserfoot opening (Fig. 4). To attain this, loosen Eccentric Ball Screw (Fig. 5) and turn Eccentric Ball until Needle reaches desired position.

REGULATING LENGTH OF STITCH

Loosen Screw (Fig. 5) in Stitch Regulating Collar and turn until desired number is by Indicator Notch in The larger the number by the notch, the longer the stitch. The smaller the number by the notch, the shorter the stitch. WHEN MAKING STITCH LONGER OR SHORTER, CHECK FEEDER WITH LOOPER AND PRESSERFOOT AS IT CHANGES POSITION OF FEEDER WHEN CHANGING LENGTH OF STITCH

FIG. 5

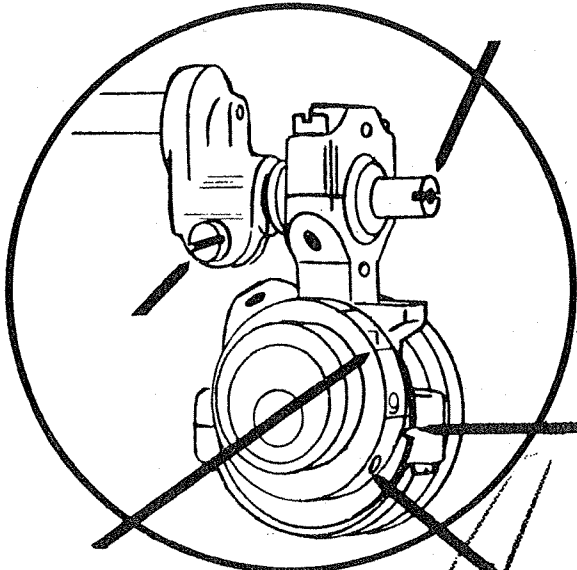

REGULATING COLLAR

NOTCH IN

FIG. 4

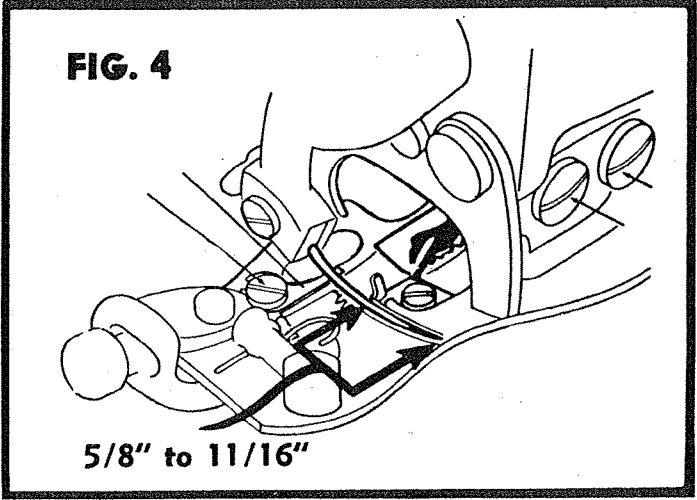

5/8" to 11/16"

Fig. 2

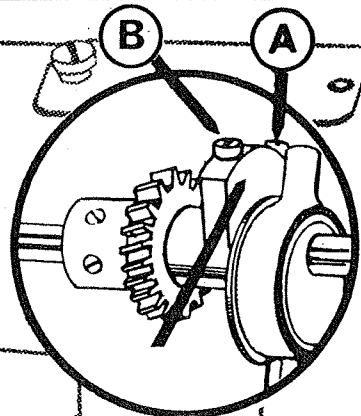

FIG. 1

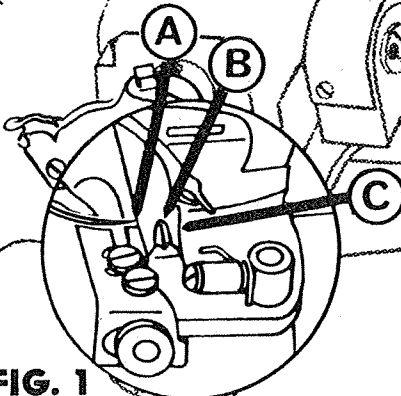
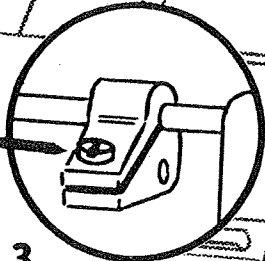

FIG. 3



ADJUSTING LOOPER

1. (FIG. 1) Loosen screw (A) to take out Looper (B) —
2. To put Looper in, be sure you put Looper in until shoulder of Looper touches shoulder of Looper Rod (C) at point (D).
3. (FIG. 2) Turn Handwheel by hand, carefully and slowly. Looper must clear the Chain-Off Pin (E) and clear needle, being just above the needle about the thickness of a sheet of paper at point (G). The long prong of the Looper should be about $3/32''$ from the needle when needle is at the limit of stroke.
4. Should Looper touch needle or Presser Foot at point (G), loosen screws (H) and use wide blade of screwdriver in slot of Eccentric Block at (J). If Looper is hitting needle, turn Eccentric Block clockwise. If Looper is too far above needle, turn Eccentric Block counterclockwise.
5. (FIG. 3) If Looper touches Presser Foot or needle at point (K) and upper part (long prong) of Looper at point (L), turn Eccentric Block clockwise.
6. (FIG. 3 & FIG. 1) Should Looper be touching at point (K) and needle touching short prong of Looper at point (L), then you must loosen nut (M) and screws (N). Then turn Looper Rod at point (C) downwards, which will clear the short prong of your Looper at point (L) and raise the Looper at point (K).
7. (FIG. 2 & FIG. 3) By turning Eccentric Block (J) clockwise or counterclockwise, it will raise or lower your Looper at points (K) and (L).

With ECCENTRIC BLOCK, you RAISE or LOWER Looper on BOTH SIDES.

TURNING LOOPER ROD, you RAISE one side and you LOWER the other side.

8. (FIG. 3 & FIG. 2) For Looper To clear Chain-Off Pin (Q) and Presser Foot at (R), Eccentric Block (J) can be moved from left to right by loosening screws (H). This will give you the desired clearance.
9. (FIG. 1 & FIG. 2) If this is necessary, be sure that Looper Rod Carrier Pin (S) is flush against Looper Rod Carrier (T) and does not have any play left or right. Secure by re-tightening screws (H).
10. (FIG. 4) When Needle Guide (U) becomes grooved or broken, remove and put in a new one. NOTE: When replacing Needle Guide, slide "U" of Needle Guide into undercut neck of screw (V). Hold together and screw on Presser Foot. Just before tightening firmly, push Needle Guide securely towards screw, hold in position and tighten Needle Guide Screw (V).
11. (FIG. 5) Feeder should be below Presser Foot a maximum of $3/32''$ at point (W) and a hair less at point (X).

(FIG. 4) BE SURE LOOPER CLEARS FEEDER AT POINT (Y).

BE DOUBLY SURE FEEDER SCREWS (Z) ARE SECURED FIRMLY.

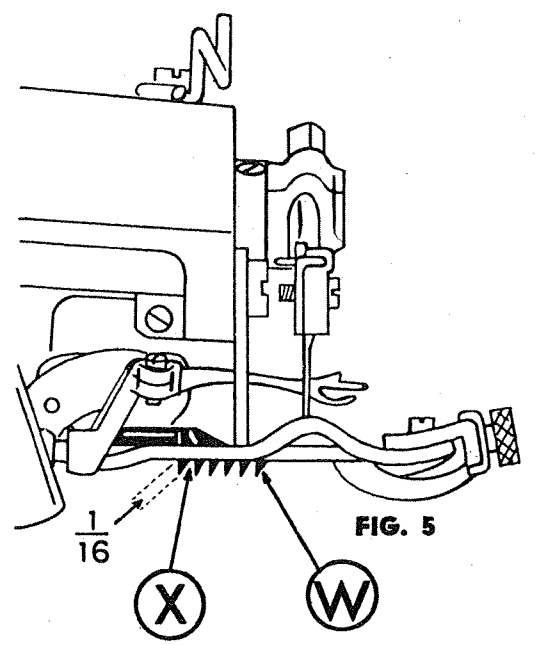
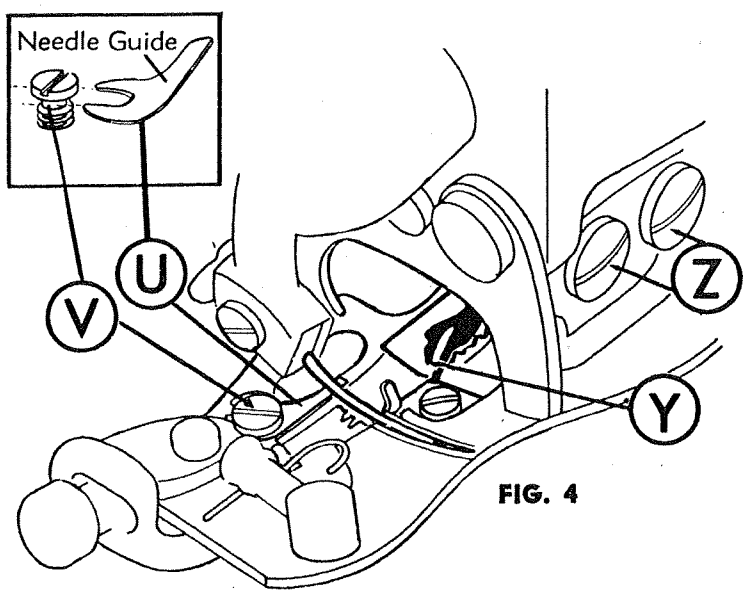
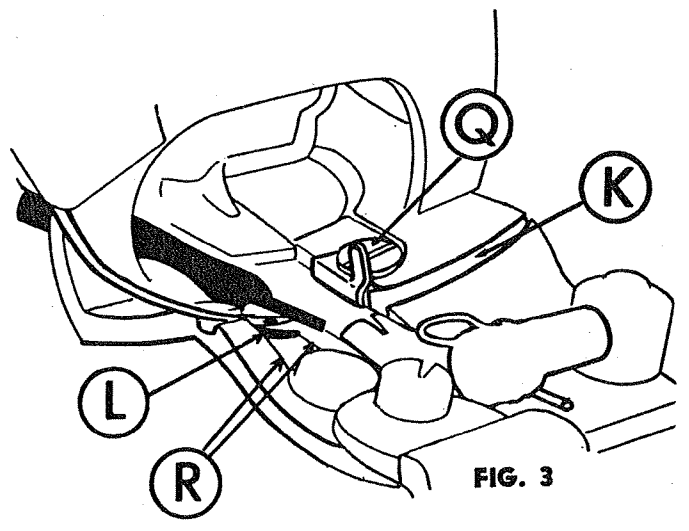
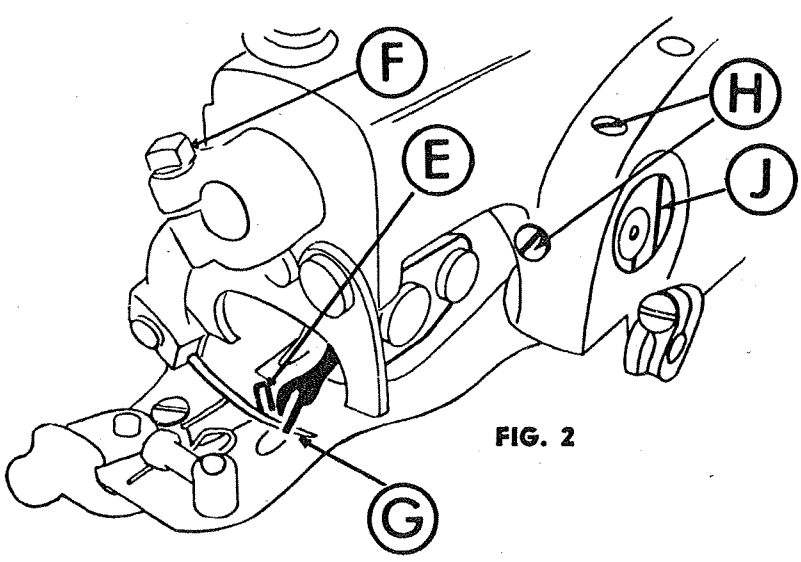
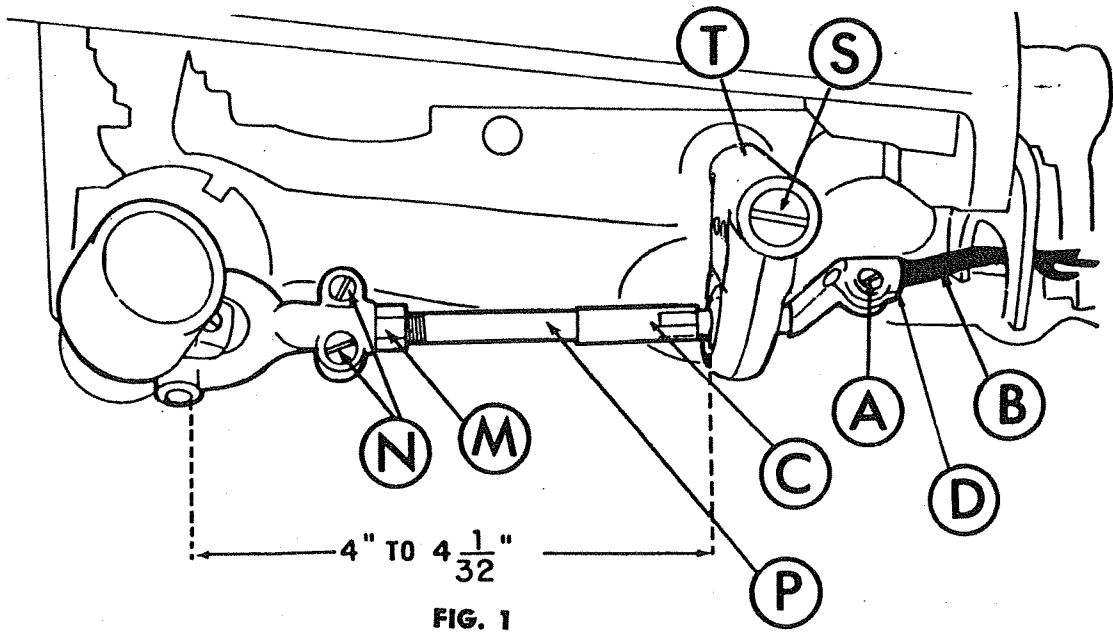

FEED FRAME

GROUP 1

- BS1030 Screw - Window plate
- BS1069 Set screw - platten bracket pivot stud
- BS1087 Rib shaft bushing - left
- BS1088 Rib shaft bushing - right
- BS1104 Screw - feed frame limit
- BS1146 Nut - feed frame limit screw lock
- BS1159 Screw - spring link lock
- BS1205 Window plate

GROUP 2

- BS1028 Spring washer - skip regulating lever stud
- BS1029 Nut - skip stitch compensating
- BS1105 Screw - skip stitch compensating
- BS1202 Skip regulating
- BS1203 Stud - skip regulating lever
- BS1332 Screw - skip regulating lever stud lock

GROUP 3

- BS1076 Screw - rib shaft collar - clamp
- BS1076 Screw - rib shaft collar - clamp
- BS1117 Screw - rib shaft crank - clamp
- BS1161 Rib shaft collar - left
- BS1162 Rib shaft collar - right
- BS1163 Crank - rib shaft
- BS1164 Stud - rib shaft crank
- BS6010 Rib shaft

GROUP 4

- BS1021 Spacer - platten bracket
- BS1055 Stop post
- BS1056 Spring post
- BS1132 Screw - platten bracket limit
- BS1166 Stud - platten bracket pivot
- BS1167 Nut - platten to bracket attaching screw
- BS1172 Spring - platten bracket
- BS1244 Screw - platten to bracket - attaching
- BS1262 Nut - platten bracket limit screw-lock
- BS2409 Platten - right
- BS2410 Platten - left
- BS2455 Platten bracket - left
- BS2456 Platten bracket - right

GROUP 5

- BS1101 Screw - cylinder cover
- BS1212 Cylinder cover

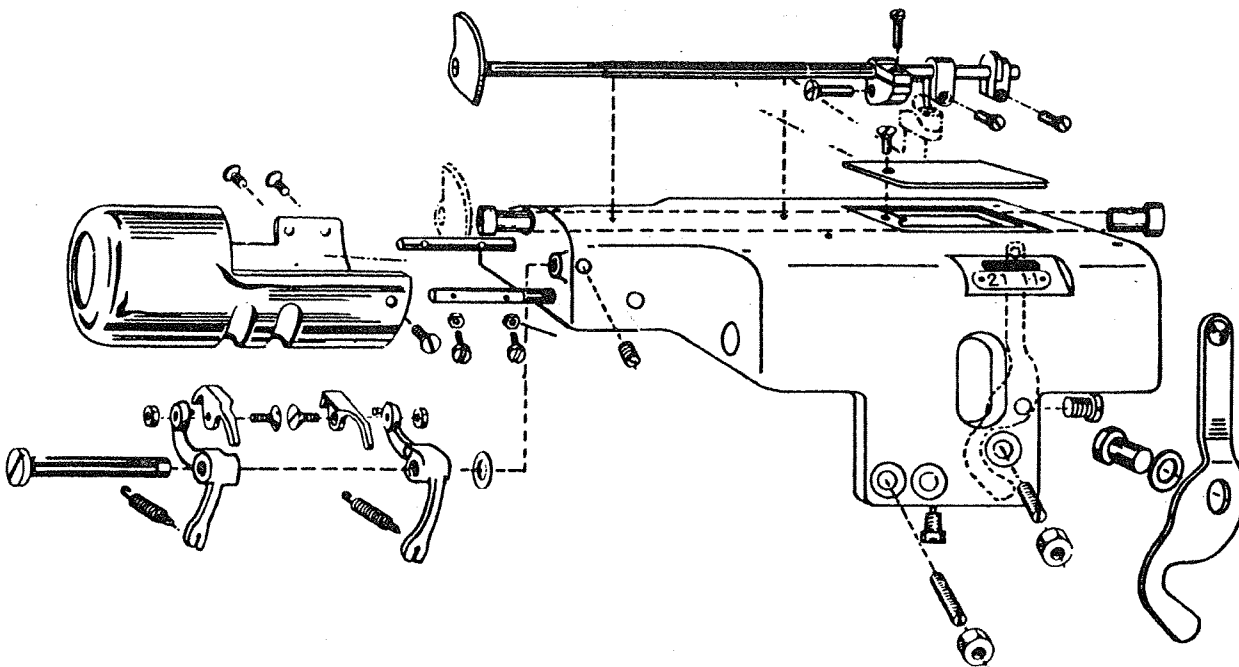

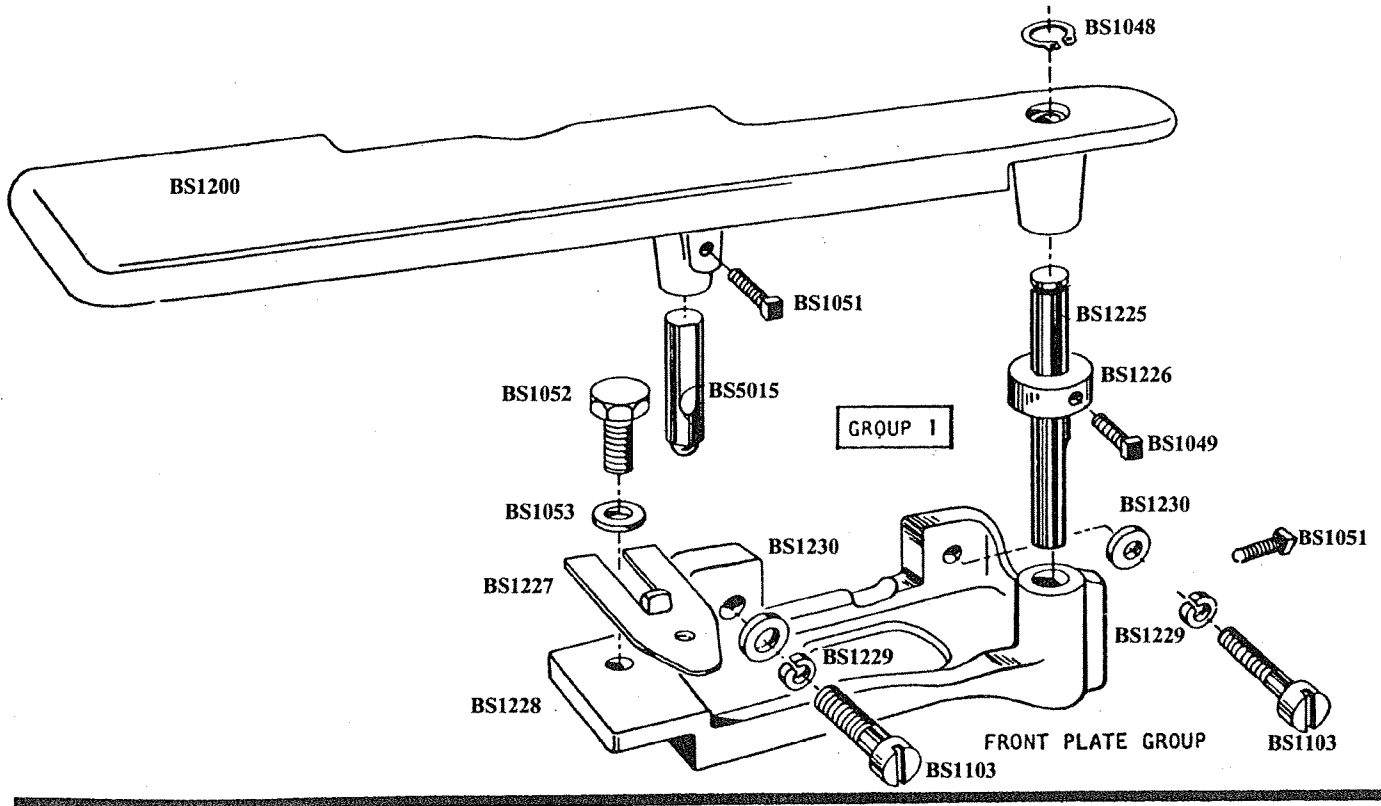

FRONT PLATE GROUP AND SUPPORT BRACKETS

BS5180	Complete plate and bracket assembly
BS1200	Swing plate
BS5015	support shaft assembly
BS1051	Screw - pivot pin-lock
BS1228	Bracket - swing plate - support
BS1052	Screw - stop plate
BS1053	Washer - stop plate screw
BS1227	Stop plate
BS1230	Washer (flat) - swing plate support bracket screw
BS1229	Washer (lock) - swing plate support bracket screw
BS1103	Screw - swing plate support bracket
BS1225	Pin - swing plate pivot
BS1048	Retaining ring - swing plate pivot pin
BS1226	Collar - swing plate pivot pin
BS1049	Set screw - swing plate pivot pin collar
BS1051	Screw - swing plate pivot pin-lock

MAIN FRAME GROUP

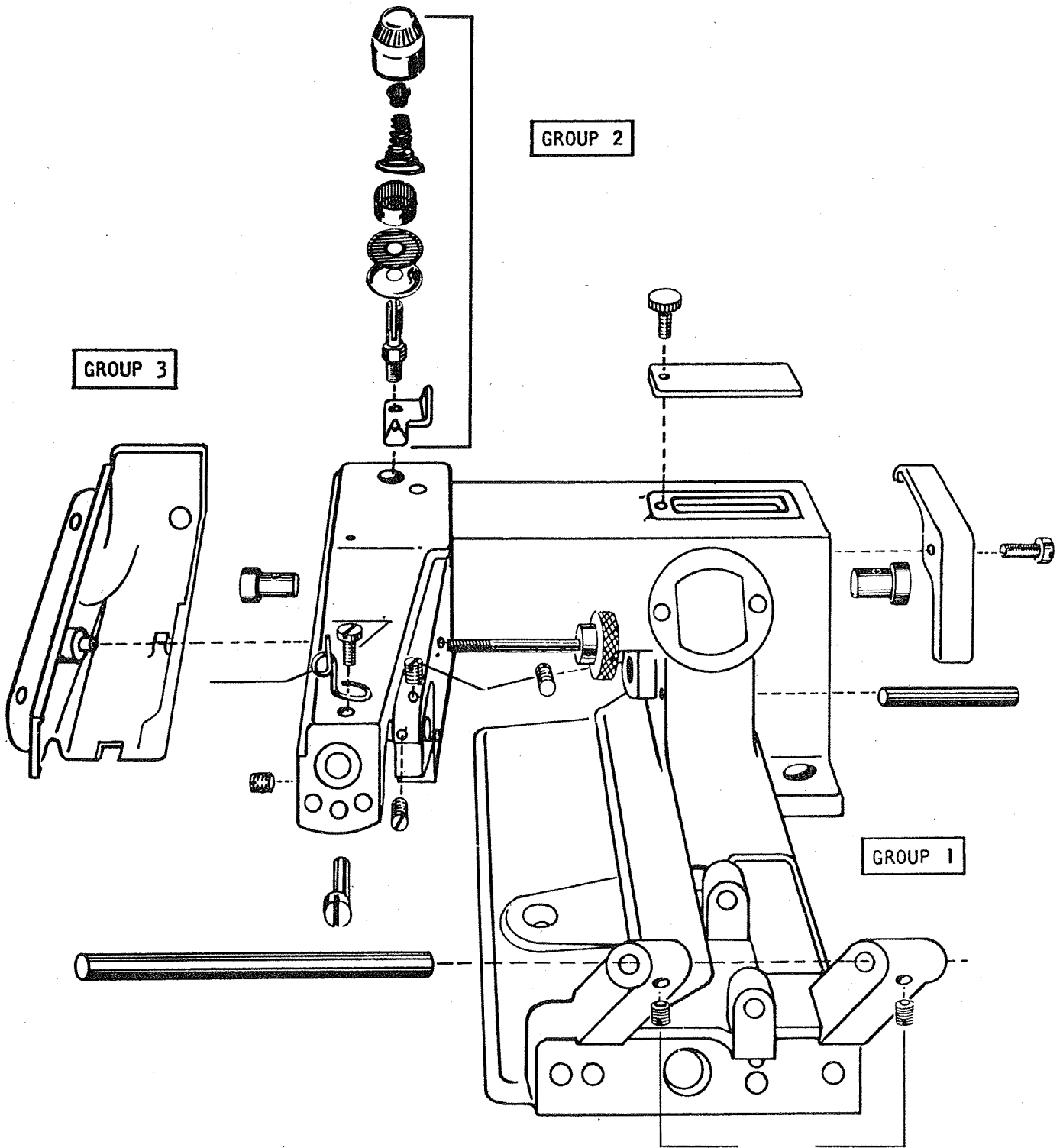

MAIN FRAME GROUP

GROUP 1

- BS1025 Pin - regulating fork-pivot
- BS1066 Shaft - feed frame rocker
- BS1068R belt guard
- BS1081 Cover plate
- BS1093 Set screw - feed frame shaft
- BS1094 Screw - eccentric pin set
- BS1096 Screw - cover plate
- BS1120R set screw - belt guard
- BS1240 Eccentric pin
- BS1289 Screw - eccentric block
- BSM1087 Main shaft bushing - left
- BSM1088 Main shaft bushing - right

GROUP 2

- BS1009 Cover
- BS1010 Nut
- BS1011 Ratchet
- BS1070 Screw - front thread guide
- BS1080 Front thread guide
- BS1082 Tension post
- BS1083 Tension discs
- BS1084 Thread guide
- BS1085 Spring
- BS5002 Tension assembly, complete

GROUP 3

- BS5001 Slide cover
- BS5019 Screw - slide cover

GROUP 4

BST5004

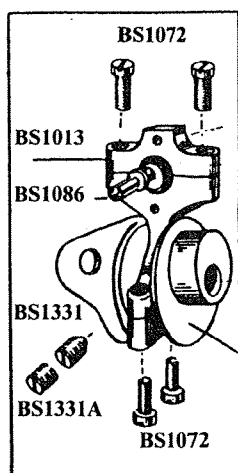

GROUP 5

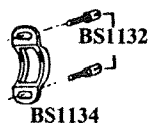

MAIN SHAFT GROUP

GROUP 5

- BS1134 Eccentric ball guard
- BS1132 Screw - eccentric ball guard

GROUP 2

- BST5003 Group 2, fitted & lapped
- BS1015 Rib connection lever
- BS1071 Screw - rib connecting lever clamp
- BS1062 Rib connection eccentric
- BS1120 Screw - rib lever eccentric

GROUP 3

- BS1043 Handwheel
- BS1121 Screw - handwheel set (cone point)
- BS1069 Screw - handwheel set

GROUP 4

- BST5004 Group 4, fitted & lapped
- BS1014 Needle and feed eccentric
- BS1331 Set screw - (cone point) feed eccentric
- BS1331A Screw - (flat) eccentric set-lock
- BS1013 Needle shaft and feed connection
- BS1086 Eccentric ball stud
- BS1072 Screw - needle connection

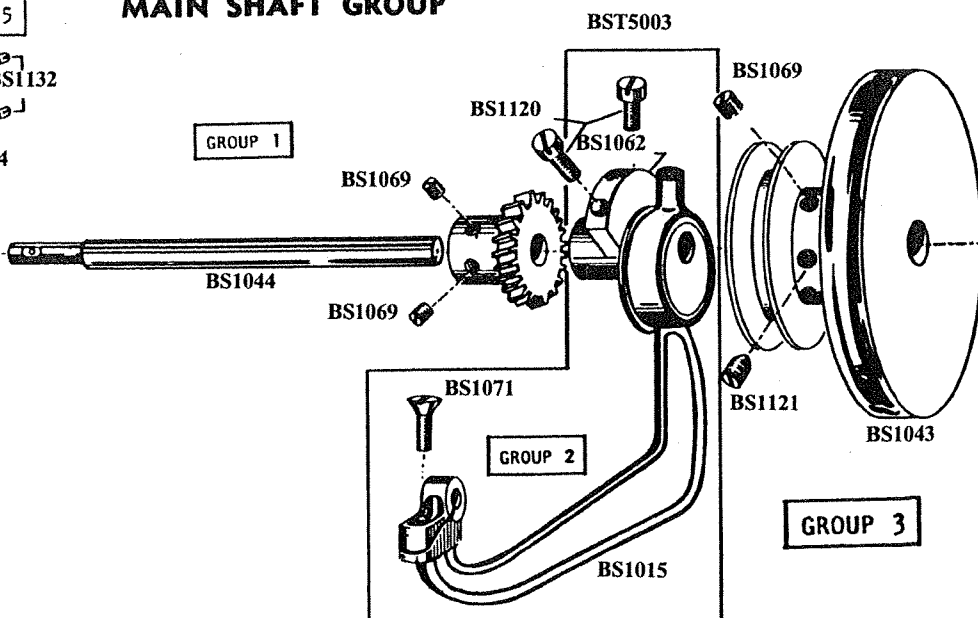

PRESSERFOOT GROUP

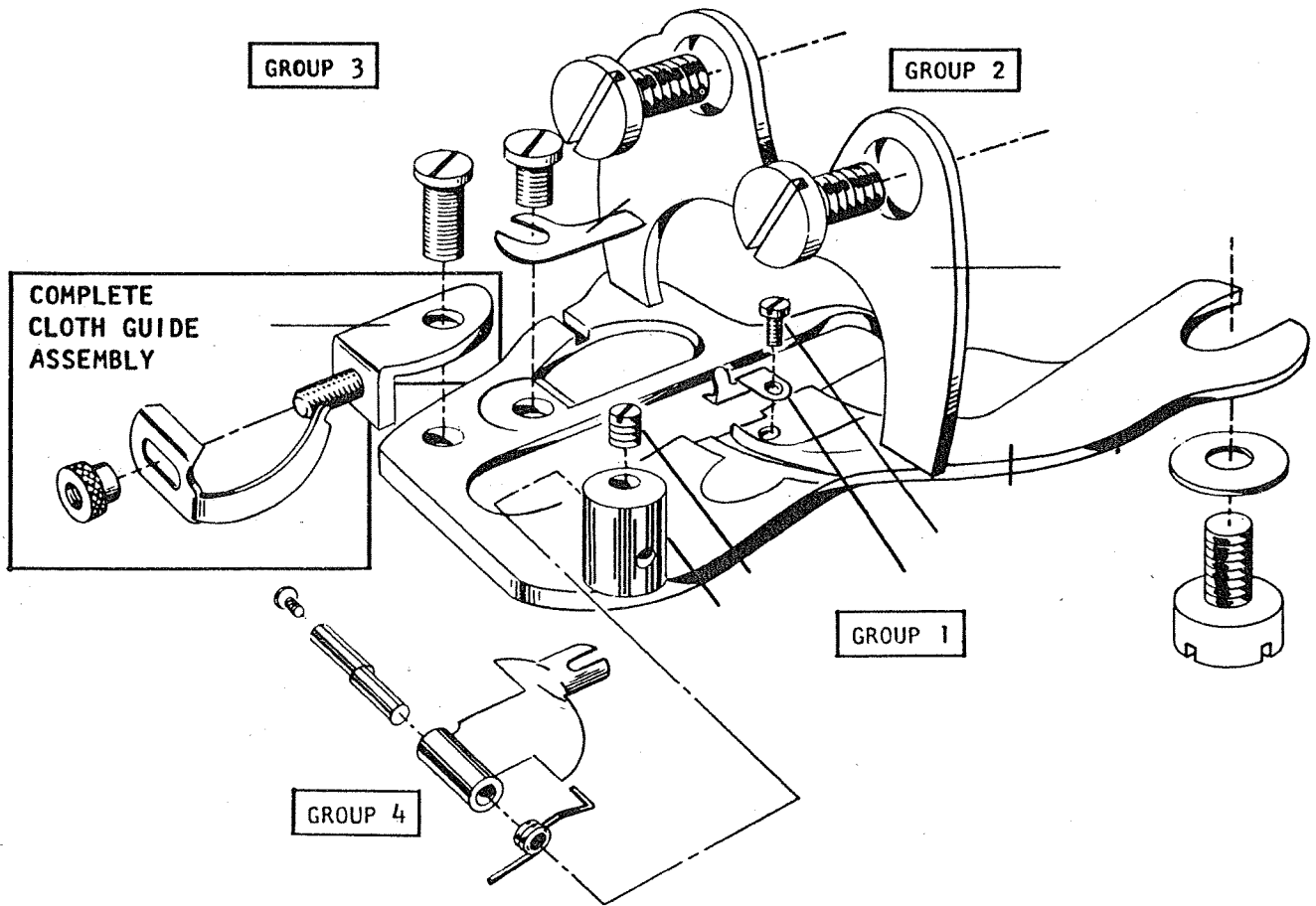

LOOPER ROD FORK SLEEVE ASSEMBLY — BST5006

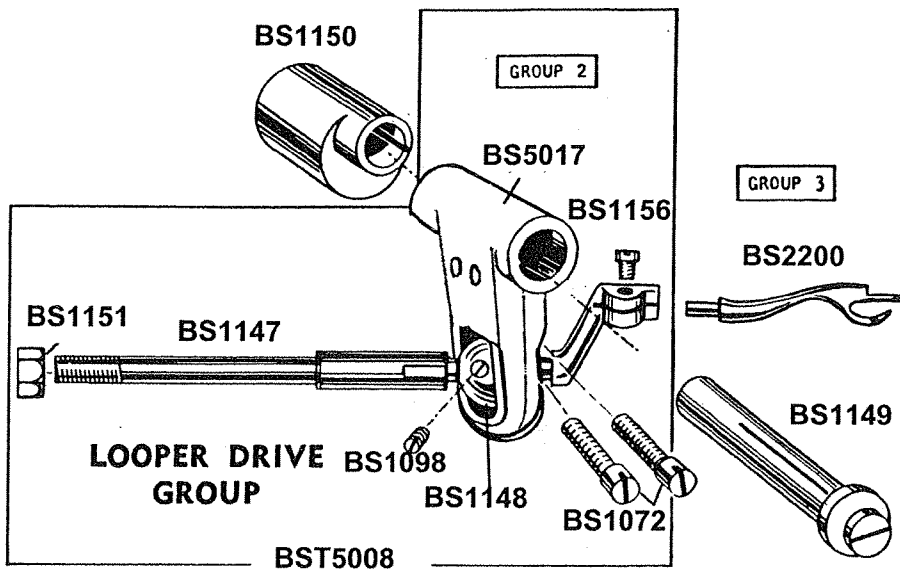
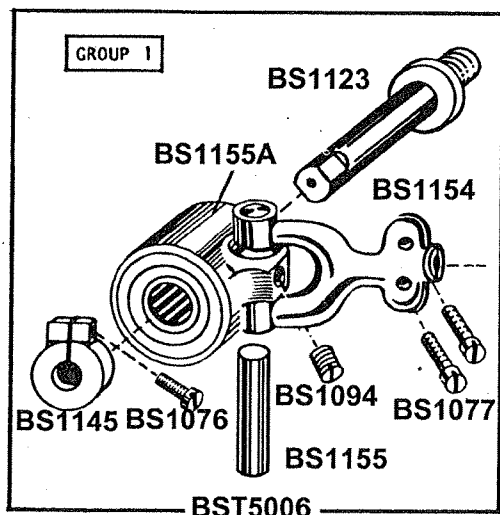

GROUP 1

- BST5006 Looper rod fork and sleeve assembly
- BS1154 Looper rod fork and sleeve assembly
- BS1155A Looper rod sleeve
- BS1155 Pin - fork and sleeve
- BS1094 Set screw - fork and sleeve
- BS1123 Stud - looper rod sleeve
- BS1145 Collar - sleeve stud
- BS1076 Screw - stud collar
- BS1077 Screw - looper rod fork-clamp

GROUP 2

- BST5008 Looper rod and carrier complete
- BS5017 Looper rod carrier
- BS1148 Looper rod ball
- BS1098 Set screw - looper rod ball
- BS1147 Looper rod
- BS1151 Nut - looper rod-lock
- BS1156 Screw - looper clamp
- BS1072 Screw - looper rod carrier-clamp

GROUP 3

- BS1149 Stud - looper rod carrier
- BS1150 Eccentric block
- BS2200 Looper

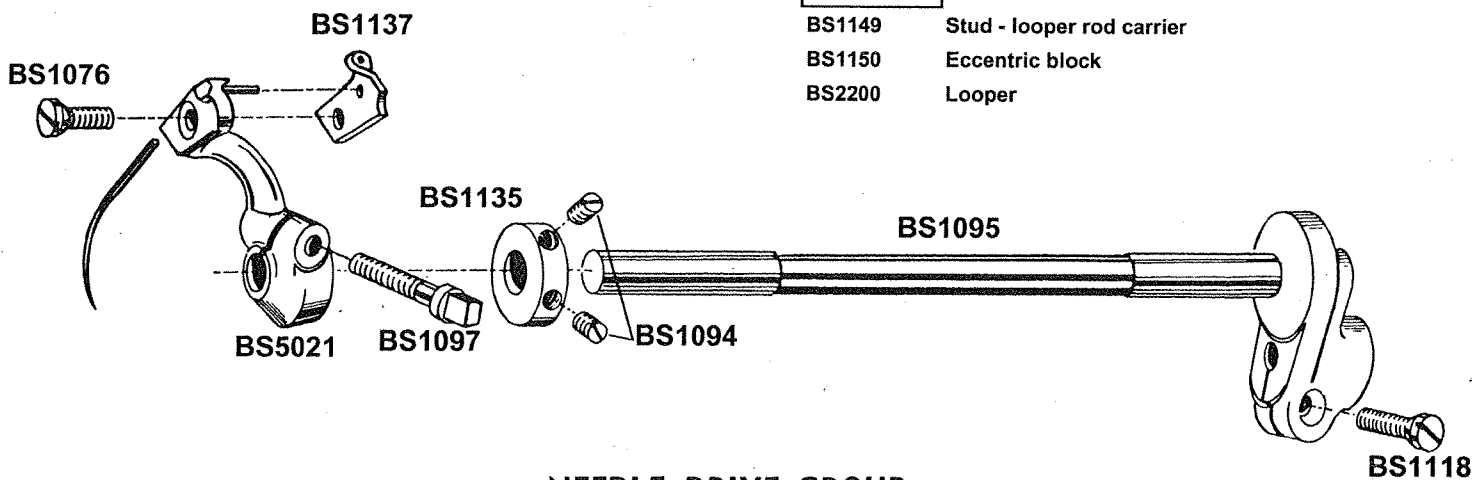

NEEDLE DRIVE GROUP

- BS5021 Needle lever
- BS1097 Screw - needle lever clamp
- BS1137 Needle clamp
- BS1076 Screw - needle clamp

- BS1095 Needle shaft
- BS1118 Screw - eccentric ball clamp
- BS1135 Collar - Needle shaft
- BS1094 Set screw - needle shaft collar

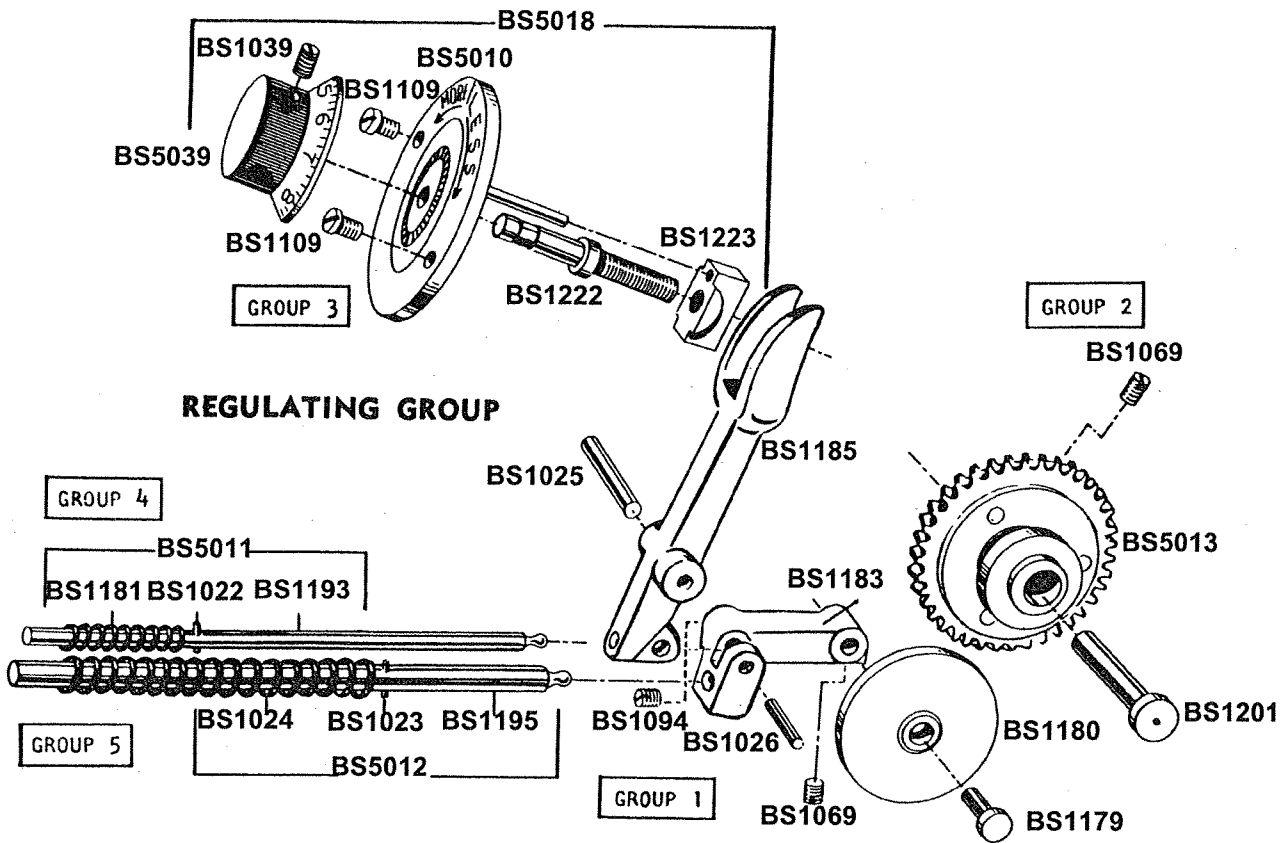

REGULATING GROUP

GROUP 1

- BS1183 Support arm - cam roller
- BS1185 Regulating fork
- BS1025 Pin - regulating fork-pivot
- BS1026 Pin - roller support arm-pivot
- BS1094 Screw - roller support arm pivot pin-set
- BS1180 Cam roller
- BS1179 Pin - cam roller support
- BS1069 Screw - cam roller support pin-set

GROUP 3

- BS5018 Regulating dial assembly
- BS1223 Regulating dial shoe
- BS1222 Regulating dial screw
- BS5010 Face plate and guide pin assembly
- BS1109 Screw - regulating dial assembly
- BS5039 Dial and ratchet assembly
- BS1039 Screw - dial and ratchet assembly-lock

GROUP 2

- BS5013 Skip eccentric gear assembly
- BS1201 Pin - skip eccentric gear
- BS1069 Screw - skip eccentric gear

GROUP 4

- BS5011 Push rod assembly
- BS1193 Push rod (1/4)
- BS1022 Cotter pin
- BS1181 Spring - push rod

GROUP 5

- BS5012 Push rod assembly
- BS1195 Push rod (3/8)
- BS1023 Cotter pin
- BS1024 Spring - push rod

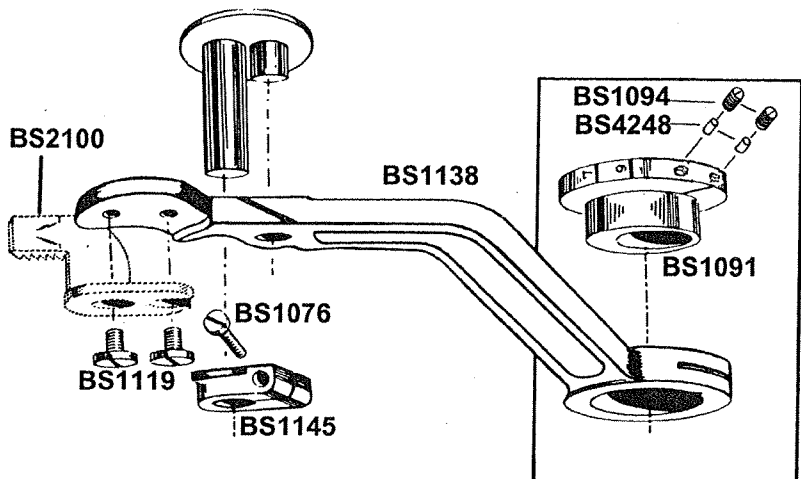

FEED DRIVE GROUP

- BS1138 Feed lever
- BS1091 Stitch regulating collar
- BS1094 Screw - titch regulating collar-clamp
- BS4248 Liner-stitch regulating collar
- BS5016 Rocker pin assembly
- BS1145 Collar - rocker pin
- BS1076 Screw - rocker pin collar-clamp
- BS2100 Feed dog
- BS2101 Feed dog fine, 20 teeth per inch
- BS1119 Screw - feed dog
- BST59138 BS1091 & BS1138 fitted and lapped

GROUP 1

- BS1060R Knee lifter rod shaft
- BS5060 Lift arm
- BS1120R Screw - lift arm clamp
- BS1008 Nut - lift arm adjusting screw-lock
- BS1035 Screw - lift arm adjustment
- BS1061 Spring - knee lifter rod-return
- BS1059 Collar - knee lifter rod
- BS1036 Set screw - knee lifter rod collar
- BS1334 Feed frame "s" hook
- BS1060C Knee lifter rod sleeve
- BS1060D Knee lifter rod sleeve screws

GROUP 2

- BS1060B Knee lifter rod
- BS1208 Knee pad
- BS1037 Knee pad screw

GROUP 3

- BS5020 Spring link assembly
- BS1191 Main spring
- BS1177 Screw - main spring link
- BS1184 Nut - Main spring adjusting
- BS1169 Nut - Spring link assembly-retaining

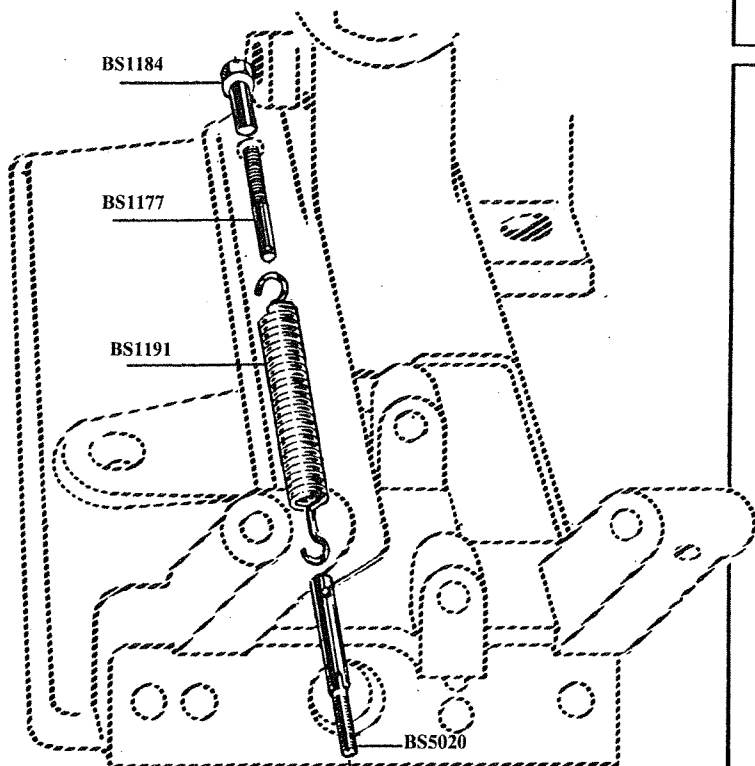
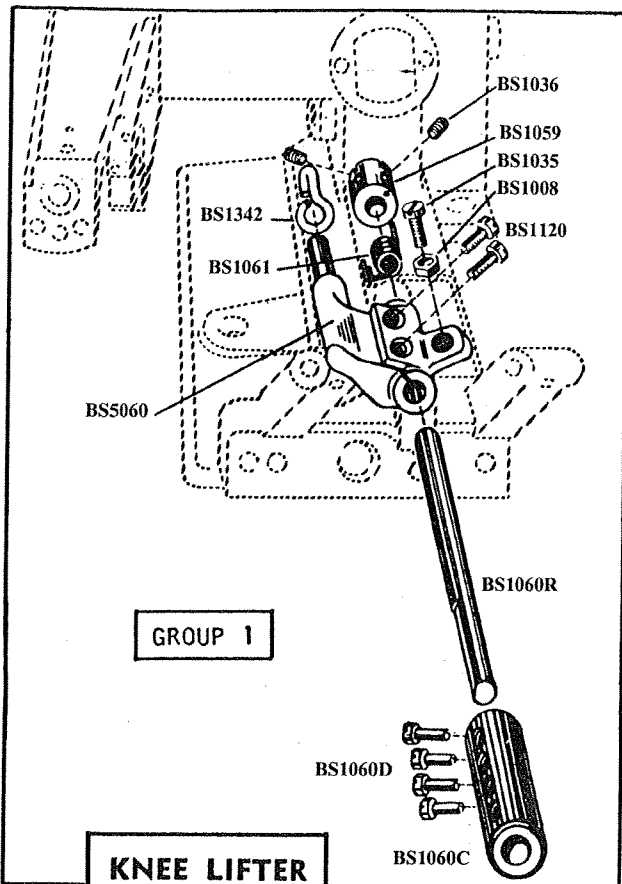
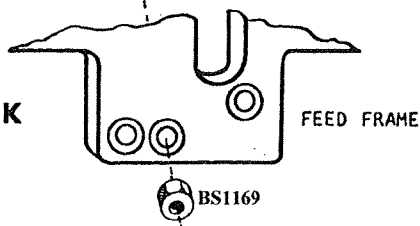
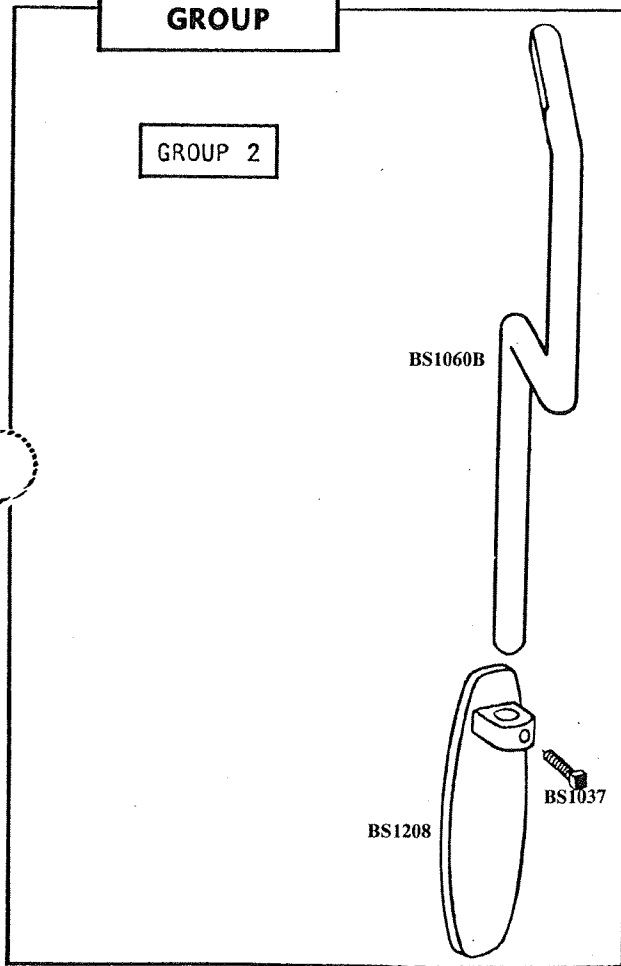
**GROUP 3****SPRING LINK GROUP****GROUP 1****KNEE LIFTER GROUP****GROUP 2**

Consolidated Sewing Machine Corp.

website: www.consew.com

MAIN office

131 W. 25th Street
New York, NY 10001
Tel: 212-741-7788
Fax: 212-741-7787
e-mail: consew@att.net

Miami, FL

7855 N.W. 29th Street, Bay 166
Miami, FL 33122
Tel: 305-471-0200
Fax: 305-471-0243
e-mail: miamisales@consew.com

Los Angeles, CA

1400 South Boradway
Los Angeles, CA 90015
Tel: 213-745-8844
Fax: 213-745-8855
e-mail: lasales@consew.com

Tokyo, Japan

28-16, Nishi-Shinkoiwa 5-Chome
Katsushika-Ku 124-0025
Tokyo, Japan
Tel: 81-3-5698-1639
Fax: 81-3-5698-1626
e-mail: info@consew.jp